

borg &
overström



Distinctive
by design.

U1

borg&
overström

High capacity, counter-top convenience

With its sleek tap and compact, high capacity S2 under-counter unit, the U1 epitomises design-led innovation. Contemporary and discreet, this electronic tap will enhance any environment.

Reasons to choose

- High capacity output
- Low energy consumption
- Compact under-counter unit
- Elegant, minimalistic design
- Discreet, hygienic control panel
- Simple-fit ventilation base included with S2



Distinctive
by design.

Water system



Direct Chill



Undercounter

Water options



Chilled



Ambient



Sparkling



Distinctive
by design.

Catering for capacity

The U1 boasts a compact yet high capacity under-counter appliance. It delivers a speedy throughput of 80 litres per hour at a consistent chilled temperature, making it the perfect solution for busy environments including Horeca applications.

Borg & Overström Totality®



Driven by a relentless pursuit of excellence, Borg & Overström Totality® is a research and development methodology for the advancement of hygiene, innovation and technology in refreshment systems.



**Laboratory certified
99.999% bacteria-reduced**
Every Borg & Overström appliance undergoes an anti-microbial, antipathogen, sanitizing procedure. The reassurance of hygienically safe appliances is provided by the unique bacteria-reducing process, Sterizen™.

Distinctive
by design.

U1 models

	Undercounter - S2 W13"xD14.5"xH14.25"	Water system	Dispense height	Tap height	Max power consumption	Stainless Steel
Power requirements Hertz 50/Volts 230	Chilled & Ambient	Dry Chill®	10.25"	16.25"	323 Watts	601501
Chilled temperature Min 35.6°F/Max 51.8°F	Chilled, Ambient & Sparkling	Dry Chill®	10.25"	16.25"	323 Watts	601502

Throughput gallons per hour
High-capacity chilled 21.1

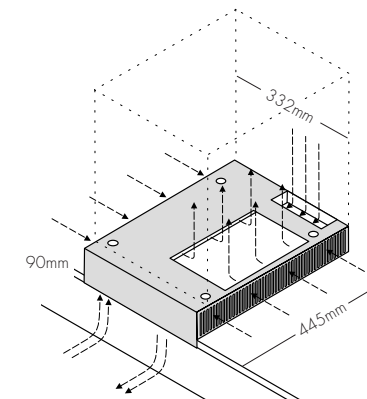

Simple-fit Ventilation Base

A refined and simple-to-install ventilation kit is included with the S2 system.

Distinctive
by design.

Additions for U1



Biodegradable paper cups
Environmentally-friendly disposable cups designed to fit Borg & Overström cup dispensers perfectly.



Personal drinking bottles
500ml capacity in black or grey frosted soft-touch finish. Comes with quick-release leak-proof cap and carry strap.



500ml glass bottles
Suitable for dishwashers and bottlewashers. Perfect fit for the U1 tap. Stylish swing-top lid.



Deep Sparkle® CO² refills
Can be disposed via standard steel recycling or general waste. Requires CO² regulator with gauge.



Sanitization kit
Six monthly sanitizing cycles ensure appliances function at the optimum hygiene levels.

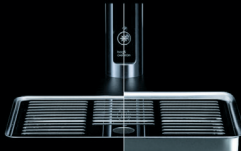

Optional drip trays
There is a range of integrated or freestanding stainless steel drip trays.



Waste kit overflow sensor
Featuring an audible high-water level alarm to prevent the waste tank from overflowing.



Mains waste kit
Mains waste kit connects the drip tray to the waste.

Distinctive
by design.

borg&
overström

Book a visit to the Borg & Overström Academy
for a personal demonstration of the U1

Talk to an adviser
+44 (0) 1362 695 006
sales@borgandoverstrom.com