

Porpoise Tap system

Dispense Options



Chilled



Hot

Contents

- Component/Feature Overview
- Operation
- Functions & Controls
- General Safety
- Fault Finding

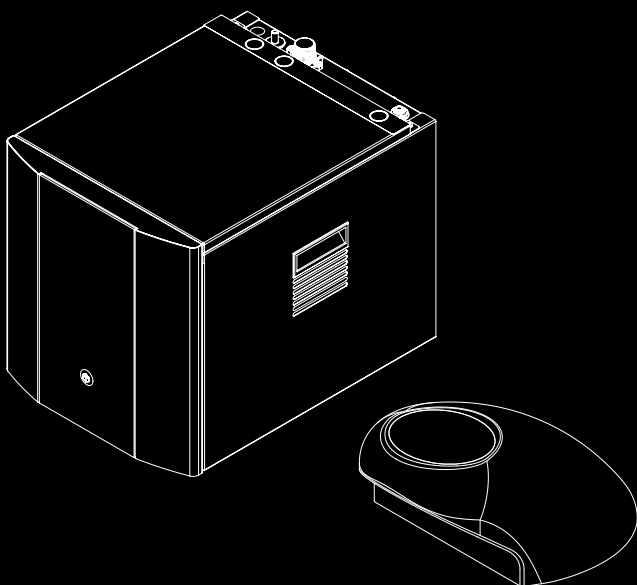

General Safety

- Always place the dispenser in its vertical position, on a surface which can capably support its weight.
- During use this machine must remain in its upright position.
- Adequate ventilation must be allowed for - we recommend using the supplied ventilation ducting kit.
- Keep the machine away from sunlight, heat and moisture.
- The environment where this machine is installed must be free of dust and corrosive/explosive gases.

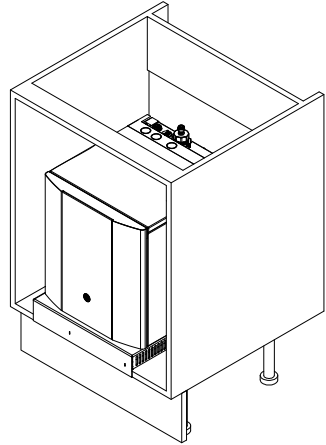

Basic Troubleshooting

Problem/Report	Possible Cause	Suggested Action
No Water Dispensing	Water Pressure Regulator	Contact your distributor
Warm Drinks	Insufficient cooling air flow through the fridge	Check that the ventilation kit has been installed correctly.
	Compressor not running	
	PCB not operating	
No Hot Water	Fridge failure	Contact your distributor
	Hot Water Tank	
	PCB not operating	

This appliance can be used by children aged from 8 years and above and persons with reduced physical, sensory or mental capabilities or lack of experience and knowledge if they have been given supervision or instruction concerning use of the appliance in a safe way and understand the hazards involved. Children shall not play with the appliance. Cleaning and user maintenance shall not be made by children without supervision.

The unit should be isolated from the electricity supply before removal of any covers. Great care must be employed when working with high pressure carbon dioxide, and in no cases should the maximum operating pressure of 0.4MPa (4 bar) be exceeded.

- The appliance is not suitable for installation in an area where a water jet could be used.
- The appliance has to be placed in a horizontal position.

WARNING: Keep ventilation openings in the appliance enclosure or in the built-in structure clear of obstruction.

WARNING: When positioning the appliance, ensure the supply cord is not trapped or damaged.

WARNING: Do not locate multiple portable socket-outlets or portable power supplies at the rear of the appliance

This appliance is intended to be used in household and similar applications such as:

- Staff kitchen areas in shops, offices and other working environments
- Farm houses and by clients in hotels, motels and other residential type environments
- Bed and breakfast type environments
- Catering and similar non-retail applications

A-weighted emission sound pressure level is below 70 dB(A)

Waste Electrical Products

- The WEEE symbol indicates that this item contains electronic components which must be collected and disposed of separately.
- Never dispose of electrical waste in general municipal waste. Collect and dispose of such waste separately.
- Make use of the return and collection systems available to you, or your local recycling programme. Contact your local authority or place of purchase to find out what schemes are available.
- Electrical and electronic equipment contains hazardous substances which, when disposed of incorrectly, may leak into the ground. This can contribute to soil and water pollution which is hazardous to human health; and endangers wildlife.
- It is essential that consumers look to re-use or recycle electrical or electronic waste to avoid it going to landfill sites or incineration without treatment.



R290/R600a

R290/R600a is a refrigerant-grade propane used on a wide range of commercial refrigeration and air conditioning units. A highly pure propane, it has a low environmental impact and nominal global warming potential (GWP), meaning it possesses no qualities that can destroy the ozone layer. R290/R600a also is the preferred hydrocarbon alternative of the Environmental Protection Agency (EPA), substituting more harmful fluorocarbon refrigerants like R22, R134a, R404a and R502. **Units with R290/R600a can only be maintained and repaired by authorized technicians who are properly trained and certified.**

Component/Feature Overview

Porpoise Tap

Contents:

- 1 no Porpoise Tap
- 2 no 1.0m Insulated Water Pipe
- 1 no Connector Cable
- 1 no Fixings Set

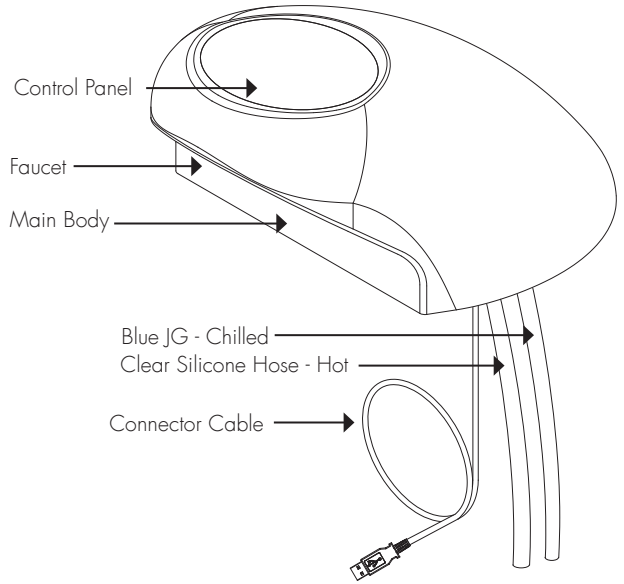

ProCore™ Undercounter

Contents:

- 1 no ProCore+ Unit
- 1 no 2.0m Power Cord Set
- 1 no Ventilation Ducting Kit

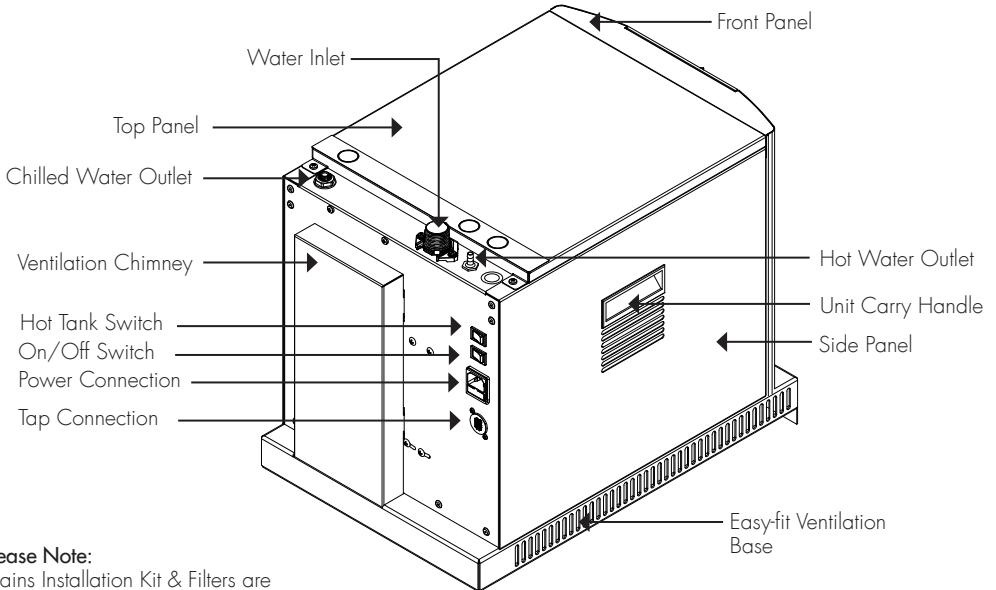

Please Note:

Mains Installation Kit & Filters are supplied as extra items according to individual ordering requirement.

Functions & Controls

Controls

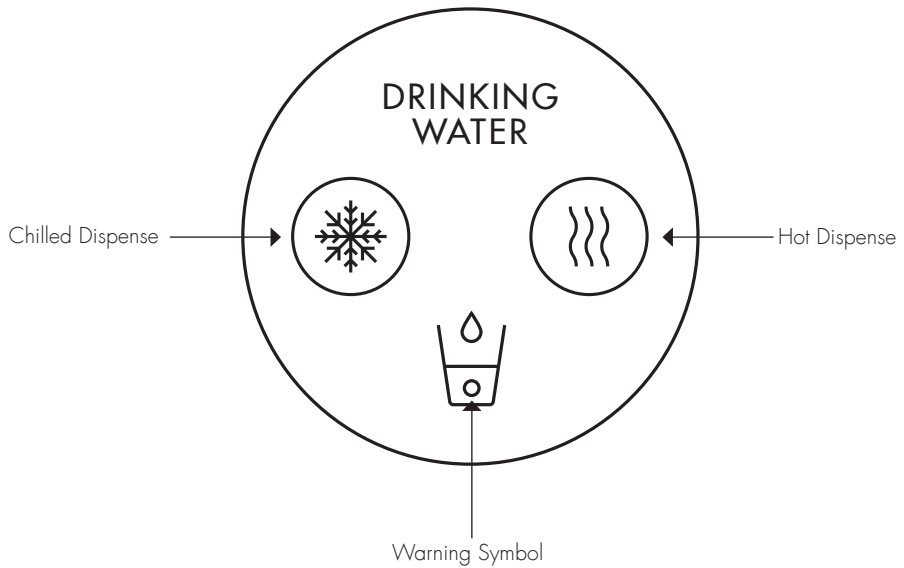

Basic Functions

Dispensing cold water from unit:

Press and hold dispense icon and release to finish dispense

Dispensing hot water from unit:

Press 'hot icon' to unlock and then press and hold to dispense.

Warning Symbol

'Warning' symbol will illuminate and flash upon a fault. The number of flashes can relate to a particular fault. Refer to the Instruction & Operation manual to diagnose.

Installation Requirements

Identify a suitable location for the ProCore unit. It should be positioned within 1.0m of the faucet, and within 2.0m of suitable services connections. Allow enough space to fit the ventilation ducting system.

The ProCore unit must be installed in accordance with the relevant requirements of:

- The appropriate building regulations by application of either The Building Regulations (England and Wales), The Building Regulations (Scotland) or The Building Regulations (Northern Ireland). In territories other than those listed the local regulations in force must be complied with.
- The Water Supply (Water Fittings) Regulations (England, Wales and Northern Ireland) or The Water Byelaws in Scotland.
- The unit must not be installed where it is liable to freeze. If the unit is thought to be frozen it must not be switched on. It should be allowed to thaw and must then be thoroughly inspected to ensure it is undamaged.

Water: Mains potable water – internally regulated to 0.3MPa (3 bar)

Ambient room operating temperature:
Min 5°C - Max 35°C

CO₂: Food Grade CO₂ to be supplied

Min mains pressure: 0.05MPa (0.5 bar) dynamic

Electricity: 10A supply – Earth Leakage Protected

Hot Tank Commissioning

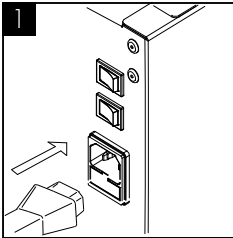

Connect the unit to the electricity supply and ensure unit is switched on.

Check hot switch is off.

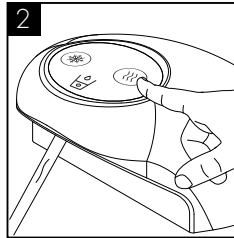

The hot versions switch will be off on delivery. Dispense from unit to ensure tank is full.

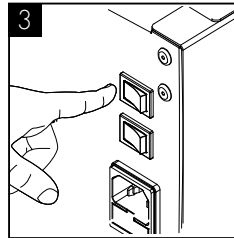

Then switch on the hot tank using the hot switch.

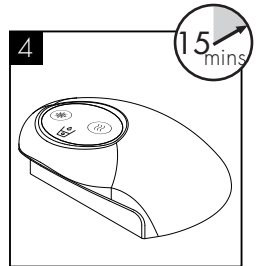

Allow the machine to stand for 15 minutes for the initial chilling and heating process to complete.

Sanitisation Guide

To be completed by a technician or service provider

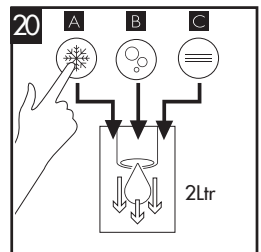
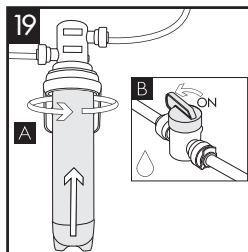
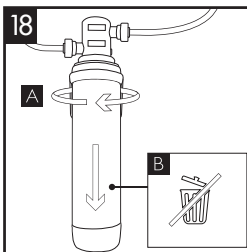
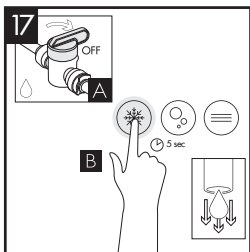
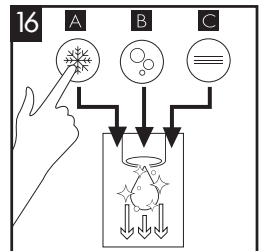
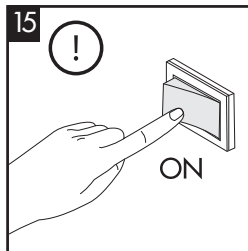
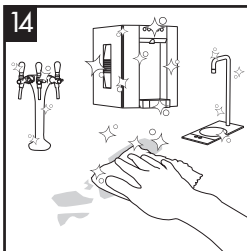
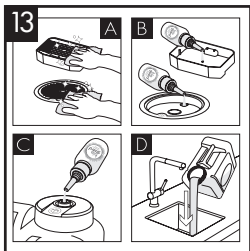
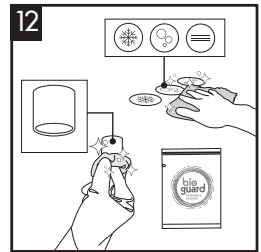
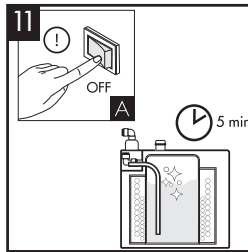
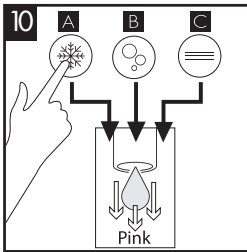
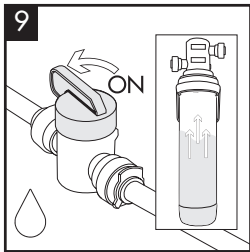
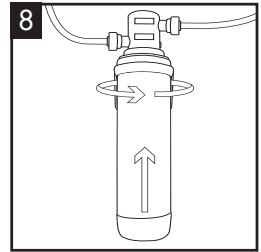
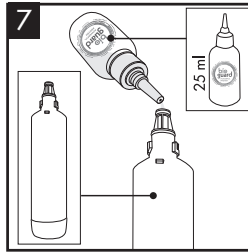
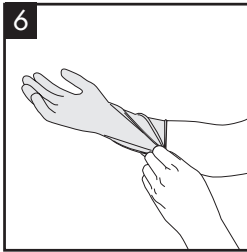
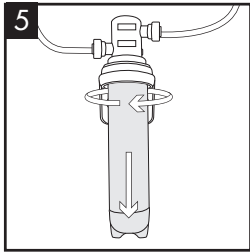
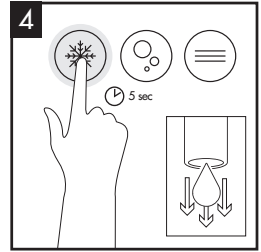
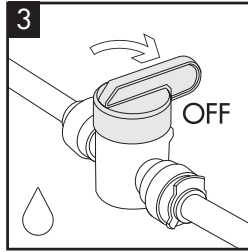
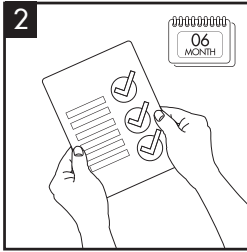
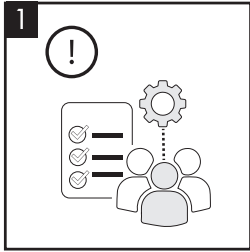

For full distributor
service manual visit:

www.borgandoverstrom.com/manual/porpoise

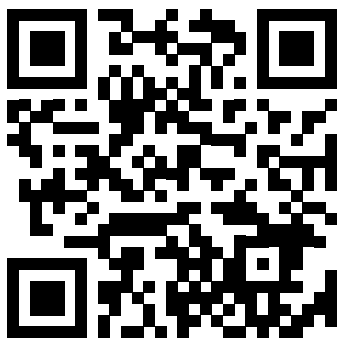

Customer services:
aftersales@borgandoverstrom.com
call +44 1362 695 006

Telephone
+44 (0)1362 695 006
Email
sales@borgandoverstrom.com

borgandoverstrom.com

© Copyright Borg & Overström.
This guide is printed by Borg & Overström and
shall not be reproduced or copied in anyway.

Ref: 702451
Version: 02